

Laboratory Airflow Controls & Monitors

EN14175 Standard

Multifunctional airflow controllers and monitors to complement corrosion resistant fan installations in laboratory fume cupboards.



About Us

Axair are an independent UK distributor of industrial fans and accessories. In addition to supply, we pride ourselves on our fan integration specialisms that ensure we provide a full service solution to our wide customer base across varied market sectors.

Our industrial applications

Chemical Storage Ventilation where ammonia, hydrogen and other corrosive fumes are present.

Fume Cupboards whether in laboratory, educational settings, extract arms, dust or fume extraction.

Environmental Fume Extraction for anaerobic and aerobic digestion plants and other toxic environments.

Biomass, Biofuel & Renewables for combustion, material handling, drying, explosion protection and corrosion management.

Sewage & Waste Water Treatment for sludge drying, toxic fume removals and eliminating hazardous gases.

Mortuary & Autopsy where formaldehyde is present and corrosive gas ventilation in down draught benches.

ATEX Applications to prevent explosions in potentially hazardous Zone 1, 2 or 0 applications.

SEAT Ventilation

SEAT is the leading EU manufacturer of plastic fans and has more than 35 years experience in their field.

As the exclusive UK distributor for SEAT, Axair are proud to work closely with the fan manufacturer to deliver superior corrosive fume, chemical, ATEX and specially designed fan components to the UK market.

Certifications & Groups

Axair are a carbon zero ISO 9001 approved company. We are proud active members of the fan manufacturers and smoke control associations. Download a copy of our certifications at www.axair-fans.co.uk.



Remote HMI Controller: Type A



The type A remote HMI controller is a safety device which monitors the fan connected to a lab fume hood. A speed sensor measures the face velocity and built in visual and audio alarms alert the user in the event of any malfunctions. On-site adjustments are possible.

Benefits

- Reliable
- No maintenance
- Easy to use and install
- Visual and audible alarms
- Pre-caliber to 0.5 m/s
- Compliant with EN 14175
- HMI monitors take up minimum space on the fume hoods and control the exhaust fan. The settings can be carried out in the lab

This controller is EN14175 and RoHS compliant	HMI Dimensions 130x40x24	CPU Dimensions 241x182x65
--	---------------------------------	----------------------------------

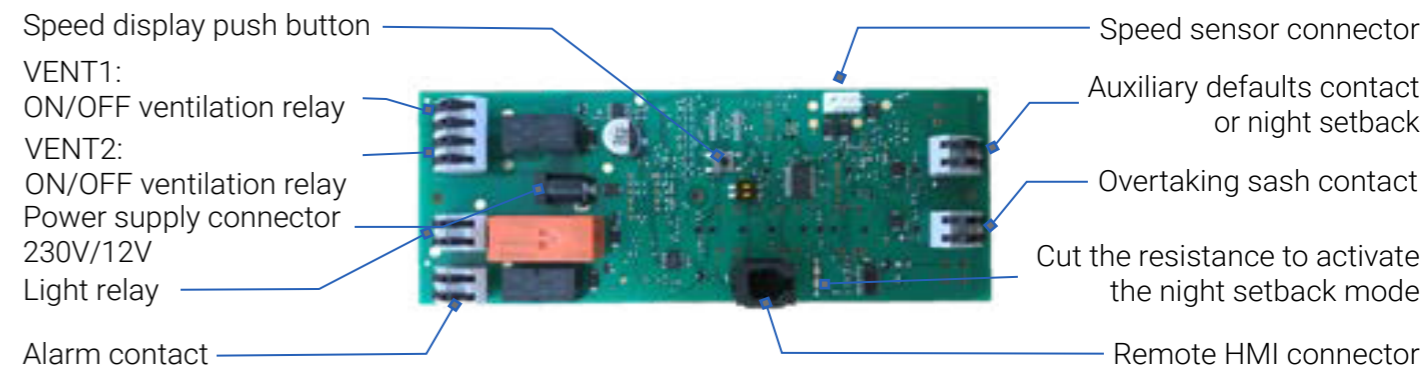

Remote HMI Controller: Type A

Diagram

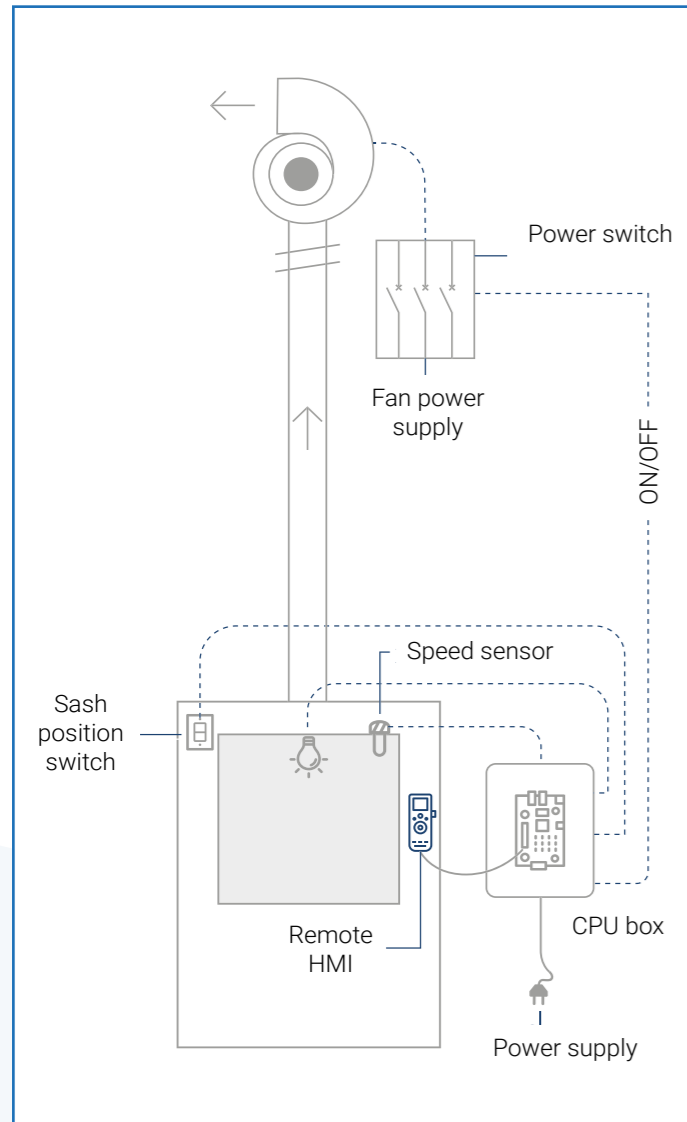

Operating Principal

The Type A remote HMI controller is used to control the ventilation of a fixed airflow fume hood.

Three push buttons are used to control the ventilation, the lighting and to stop the alarm.

Pressing the ON/OFF ventilation button on the HMI controls a fan and/or a motorised damper via the two relays VENT 1 and VENT 2.

The sensor measures the front speed and the controller informs the user by means of several indicators.

The green LED is lit when the face velocity is sufficient.

The red LED flashes when the face velocity is insufficient.

The orange (sash overrun) LED lights up if the sash is raised above the maximum safe working opening. This fault is triggered by a position switch.

The orange (auxiliary faults) LED lights up if the auxiliary input is activated.

If a failure remains within a 15-30 second period the audible alarm will activate. Once the fault is located the stop buzzer button can be used to stop the alarm.

Pressing the light ON/OFF button controls the lighting via a 250V 16A relay. The controller is supplied with a 230V/12V power adaptor.

The controller is factory preset to 0.5m/s and can be reset on site using an anemometer.

Options

- Available in vertical or horizontal version
- Available in digital display version (m/s)
- Battery
- Alarm relay
- Temperature sensor
- Night setback
- Speed sensor with 5 metres wire

Remote HMI Controller: Type C



The TYPE C remote HMI controller is a safety device for controlling the ventilation of a fume hood using a PID controller. It adjusts the ventilation to maintain the set speed regardless of the height of the glass. Visual and audible alarms alert the user if a malfunction occurs.

Benefits

- PID controller
- No maintenance
- Easy to use, install and maintain
- Very reliable
- Remote HMI with small dimensions to control the fume hood ventilation and to make adjustments on site
- Energy savings (reduction of exhaust air by regulation)
- Flexibility (the fan can be set to any speed)
- Ease of use: low air speeds ensure low noise levels
- Pre-caliber to 0.5 m/s
- Compliant with EN 14175

This controller is EN14175 and RoHS compliant	HMI Dimensions 130x40x24	CPU Dimensions 241x182x65
--	------------------------------------	-------------------------------------

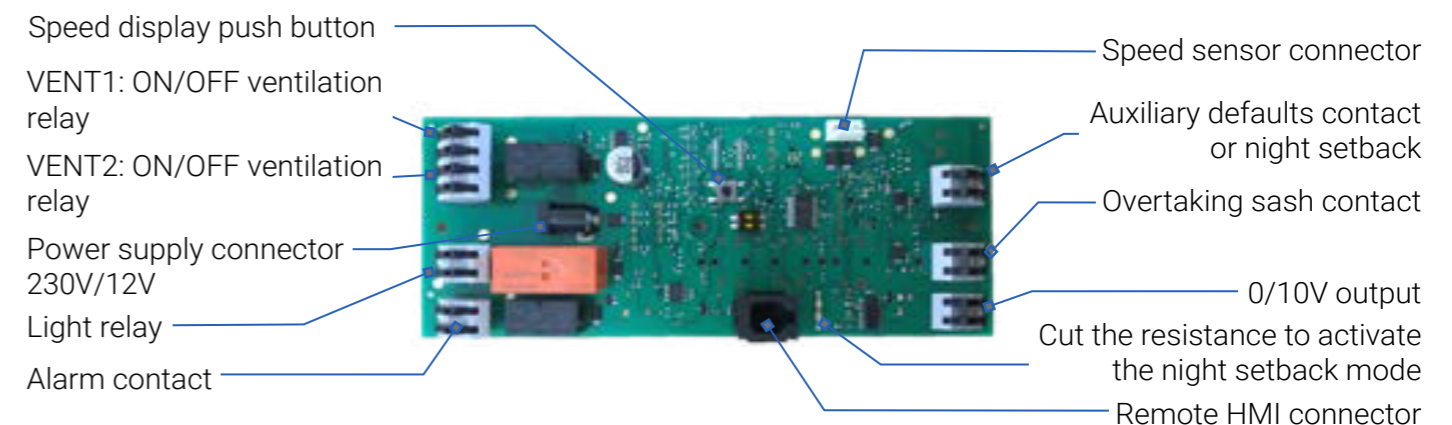

Remote HMI Controller: Type C

Diagram

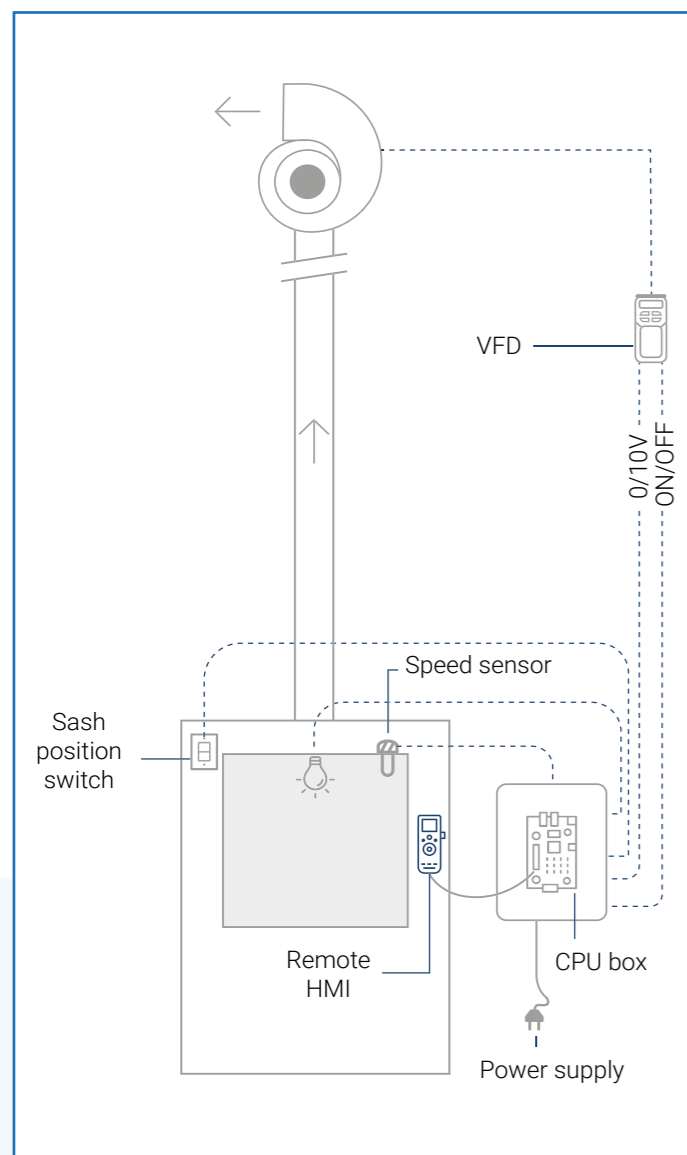

Operating Principal

The type C remote HMI airflow controller is used to control the airflow of a fume hood.

Three push buttons are used to control the ventilation, the lighting and to stop the alarm.

Pressing the ON/OFF ventilation button on the HMI controls a fan and/or a motorised damper via the two relays VENT 1 and VENT 2.

The sensor measures the face velocity, and the controller modulates the 0/10V signal with a PID controller to maintain the speed setpoint regardless of the window height. This analogue signal is sent to the VFD or motorised damper to modify the flow rate.

The green LED is lit when the face velocity is sufficient.

The red LED flashes when the face velocity is insufficient.

The orange «sash overrun» LED lights up if the sash is raised above the maximum safe working opening. This fault is triggered by a position switch.

The orange LED «auxiliary faults» lights up if the auxiliary input is activated.

If a failure remains within a period of time of 15-30s, the audible alarm will activate. Having identified the problem, the laboratory personnel can stop the alarm by pushing the stop buzzer button.

Pressing the light ON/OFF button controls the lighting via a 250V 16A relay.

The controller is supplied with a 230V/12V power adaptor and is factory preset to 0.5m/s, it can be reset on site using an anemometer.

Options

- Available in vertical or horizontal version
- Available in digital display version (m/s)
- Battery
- Alarm relay
- Temperature sensor
- Night setback
- Speed sensor with 5 metres wire

Remote HMI Controller: Type C 2 - Speed



The TYPE C 2-speed remote HMI controller is a safety device that regulates the airflow according to a low and high speed depending on the sash position. The controller engages the second speed by means of a switch placed on the sash path. It informs the user with visual and audible alarms if a malfunction occurs. The remote HMI enables adjustments on site and controls the fume hood ventilation.

Benefits

- Suitable to all types of fume hood
- Immediate change in flow rate
- High stability of the extracted flow rate
- Noise reduction
- Energy savings
- No maintenance
- Easy to use
- Very high reliability
- EN 14175 compliance

This controller is EN14175 and RoHS compliant	HMI Dimensions 130x40x24	CPU Dimensions 241x182x65
--	-------------------------------------	--------------------------------------

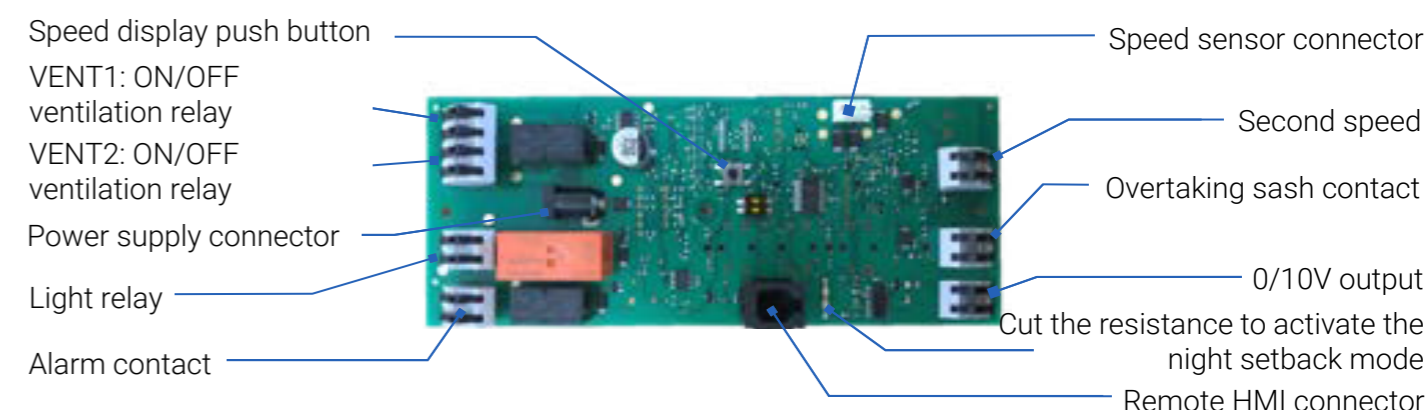

Remote HMI Controller: TYPE C 2 - SPEED

Diagram

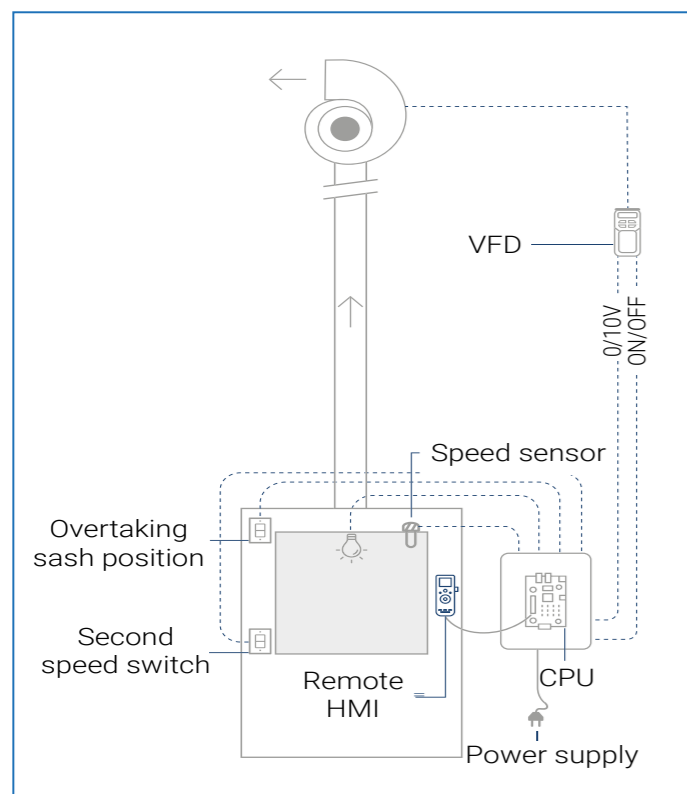

It allows regulation of the ventilation according to 2 operating points determined by the position of the sash.

- In the low position, the controller sends a first fixed voltage.
- In high position, the controller sends a second fixed voltage.

The switch allows to alternate from one speed to another. The controller ensures both the safety of the operator and an important energy saving.

The green LED is lit when the face velocity is sufficient.

The red LED flashes when the face velocity is insufficient.

The orange «sash overrun» LED lights up if the sash is raised above the maximum safe working opening. This fault is triggered by a position switch.

The orange LED «auxiliary faults» lights up if the auxiliary input is activated.

If a failure remains within a period of time of 15-30s, the audible alarm will activate.

Having identified the problem, the laboratory personnel can stop the alarm by pushing the stop buzzer button.

Pressing the light ON/OFF button controls the lighting via a 250V 16A relay.

The controller is supplied with a 230V/12V power adaptor.

The controller is factory preset to 0.5m/s and can be reset on site using an anemometer.

Options

- Available in vertical or horizontal version
- Available in digital display version (m/s)
- Battery
- Alarm relay
- Temperature sensor
- Night setback
- Speed sensor with 5 metres wire

Operating Principal

The TYPE C 2-speed remote HMI flow controller controls the airflow of a fume hood. Three push buttons are used to control the ventilation, the lighting and to stop the alarm.

Pressing the ON/OFF ventilation button on the HMI controls a fan and/or a motorised damper via the two relays VENT 1 and VENT 2.

Fully Integrated Controller: Type A



The TYPE A controller is a security device which monitors the fan from a lab fume hood. A speed sensor measures the face velocity. It informs the user with visual and audible alarms if a malfunction occurs. On-site adjustments are possible.

Benefits

- No maintenance
- Easy to use, install and maintain
- Very high reliability
- Visual and audible alarm
- EN 14175 compliant

This controller is EN14175 and RoHS compliant

HMI Dimensions 210x75x34

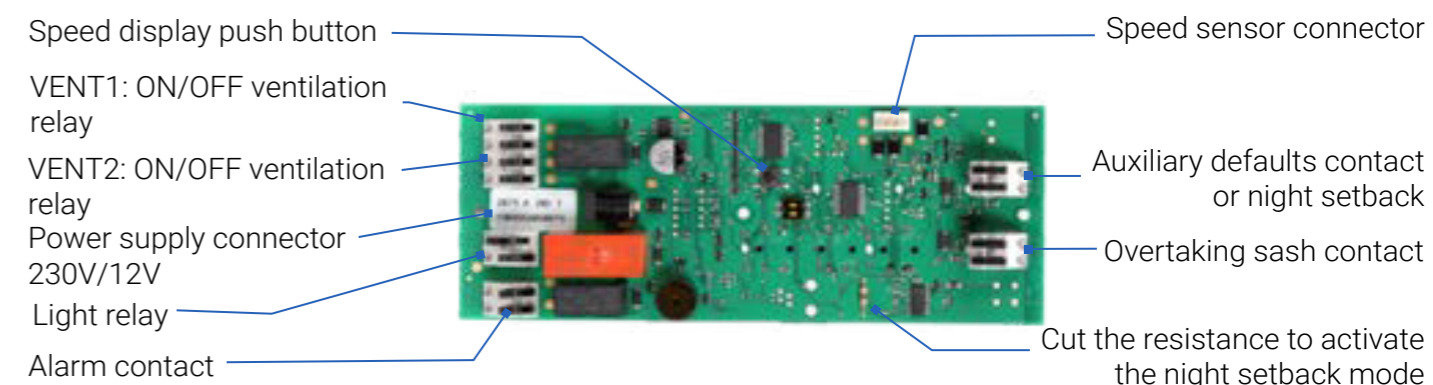

Fully Integrated Controller: Type A

Diagram

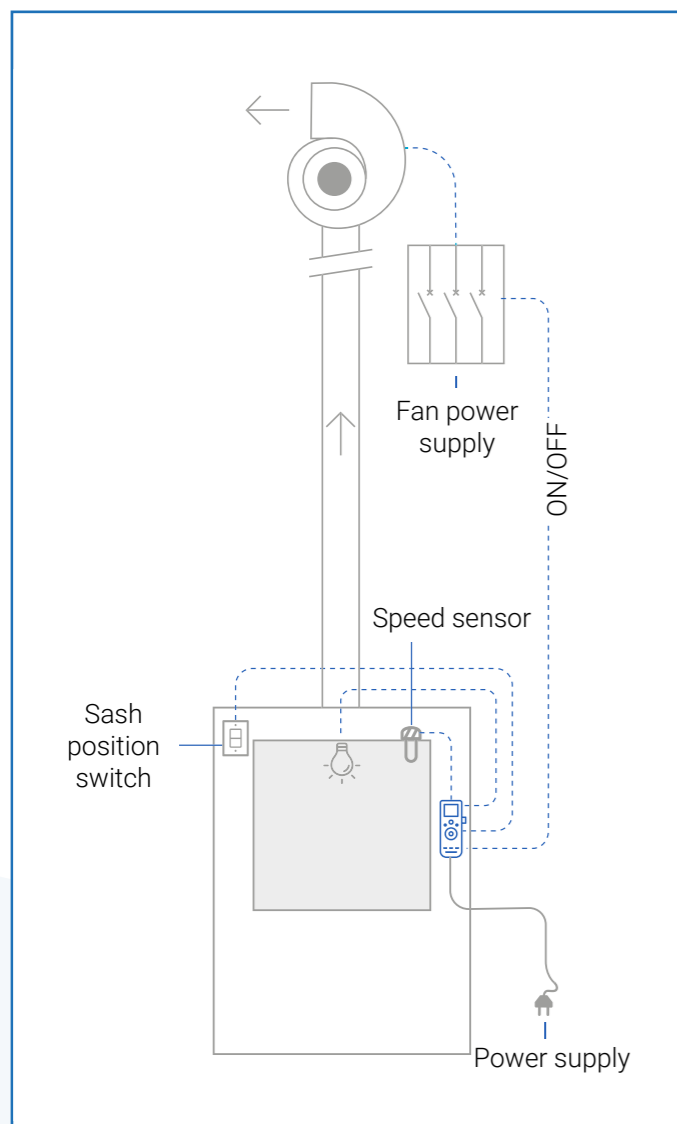

Operating Principal

The TYPE A controller is used to control the ventilation of a fixed airflow fume hood.

Three push buttons are used to control the ventilation, the lighting and to stop the alarm.

Pressing the ON/OFF ventilation button on the HMI controls a fan and/or a motorised damper via the two relays VENT 1 and VENT 2.

The sensor measures the front speed and the controller informs the user by means of several indicators.

The green LED is lit when the face velocity is sufficient.

The red LED flashes when the face velocity is insufficient.

The orange «sash overrun» LED lights up if the sash is raised above the maximum safe working opening. This fault is triggered by a position switch.

The orange LED «auxiliary faults» lights up if the auxiliary input is activated.

If a failure remains within a period of time of 15-30s, the audible alarm will activate.

Having identified the problem, the laboratory personnel can stop the alarm by pushing the stop buzzer button.

Pressing the light ON/OFF button controls the lighting via a 250V 16A relay.

The controller is supplied with a 230V/12V power adaptor.

The controller is factory preset to 0.5m/s and can be reset on site using an anemometer.

Options

- Available in vertical or horizontal version
- Available in digital display version (m/s)
- Battery
- Alarm relay
- Temperature sensor
- Night setback
- Speed sensor with 5 metres wire

Fully Integrated Controller: Type C



The TYPE C controller is a safety device for controlling the ventilation of a fume hood using a PID controller. It adjusts the ventilation to maintain the set speed regardless of the height of the glass. It informs the user with visual and audible alarms if a malfunction occurs. The remote HMI enables adjustments on site and controls the fume hood ventilation.

Benefits

- No maintenance
- Easy to use, install and maintain
- Very high reliability
- Energy savings: reduction of exhaust air by regulation
- Flexibility: the fan can be set to any speed
- Comfortable to use: low air speeds ensure low noise levels
- Visual and audible alarm
- Pre-caliber to 0.5m/s
- EN 14175 compliant

This controller is EN14175 and RoHS compliant

HMI Dimensions 210x75x34

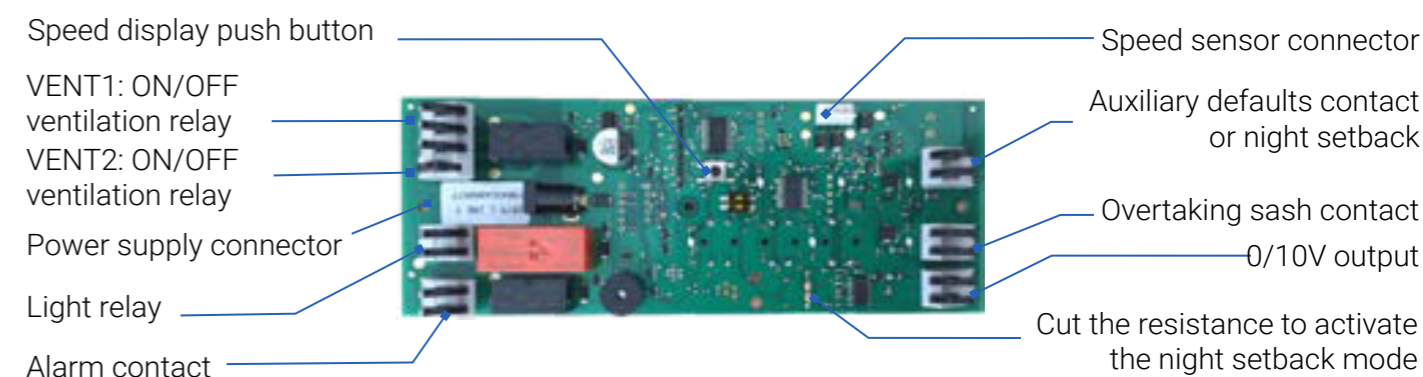

Fully Integrated Controller: Type C

Diagram

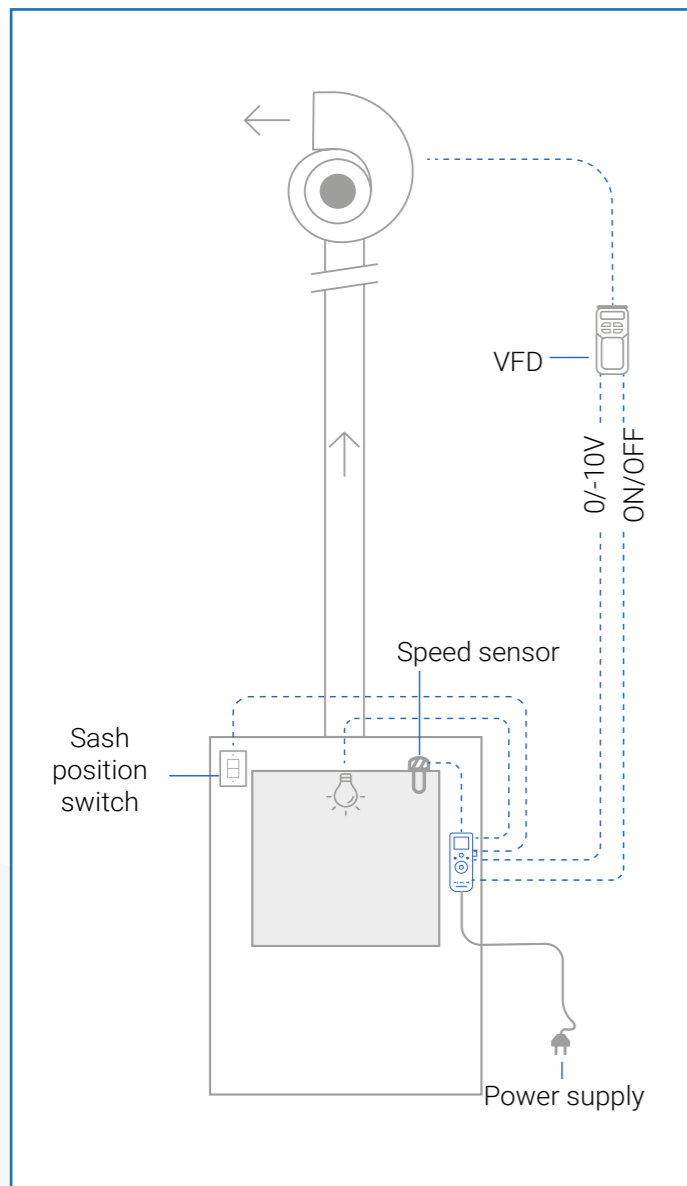

Operating Principal

The Type C airflow controller is used to control the airflow of a fume hood.

Three push buttons are used to control the ventilation, the lighting and to stop the alarm.

Pressing the ON/OFF ventilation button on the HMI controls a fan and/or a motorised damper via the two relays VENT 1 and VENT 2.

The sensor measures the face velocity, and the controller modulates the 0/10V signal with a PID controller to maintain the speed setpoint regardless of the window height. This analogue signal is sent to the VFD or motorised damper to modify the flow rate.

The green LED is lit when the face velocity is sufficient.

The red LED flashes when the face velocity is insufficient.

The orange «sash overrun» LED lights up if the sash is raised above the maximum safe working opening. This fault is triggered by a position switch.

The orange LED «auxiliary faults» lights up if the auxiliary input is activated.

If a failure remains within a period of time of 15-30s, the audible alarm will activate. Having identified the problem, the laboratory personnel can stop the alarm by pushing the stop buzzer button.

Pressing the light ON/OFF button controls the lighting via a 250V 16A relay.

The controller is supplied with a 230V/12V power adaptor, is factory preset to 0.5m/s and can be reset on site using an anemometer.

Options

- Available in vertical or horizontal version
- Available in digital display version (m/s)
- Battery
- Alarm relay
- Temperature sensor
- Night setback
- Speed sensor with 5 metres wire

Fully Integrated Controller: Type C2 - Speed

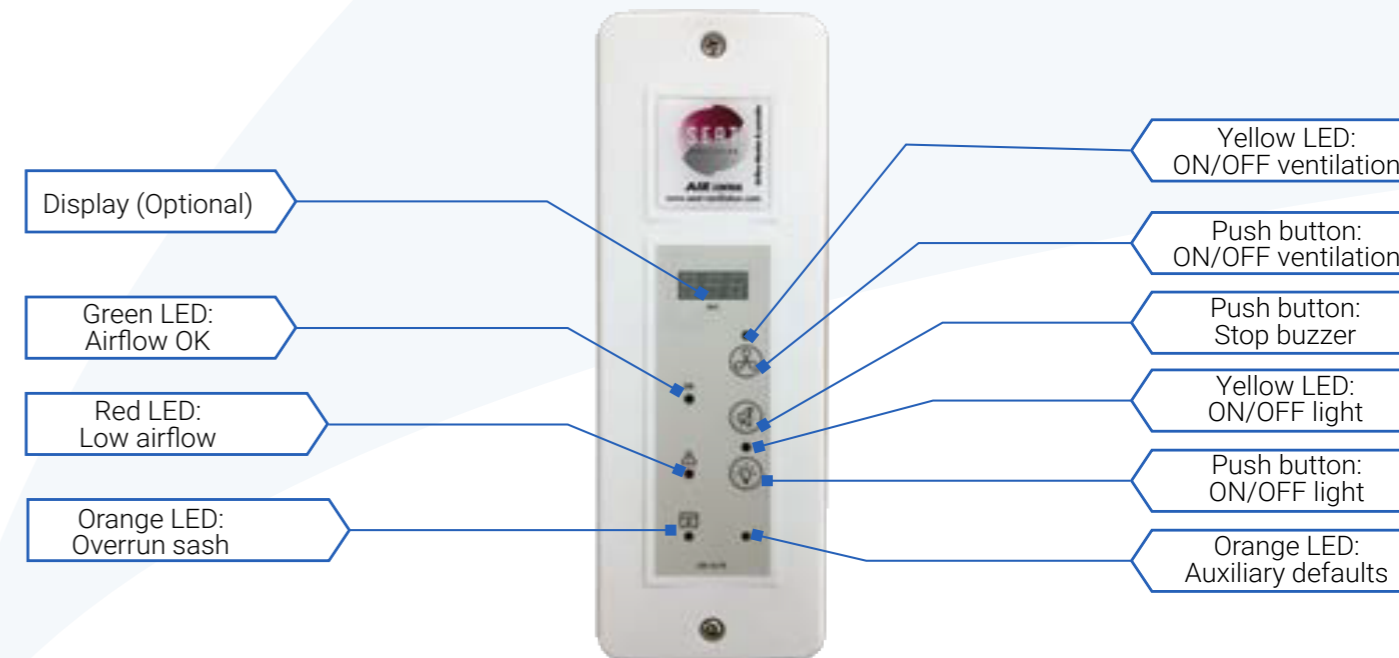

The TYPE C 2-speed controller is a safety device that regulates the airflow according to a low and high speed depending on the sash position. The controller engages the second speed by means of a switch placed on the sash path. It informs the user with visual and audible alarms if a malfunction occurs. The remote HMI enables adjustments on site and controls the fume hood ventilation.

Benefits

- Immediate change in flow rate
- High stability of the extracted flow rate
- Energy saving
- Comfortable to use: low air speeds ensure low noise levels
- No maintenance
- Easy to use
- Very high reliability
- EN 14175 compliant

This controller is EN14175 and RoHS compliant

HMI Dimensions 210x75x34

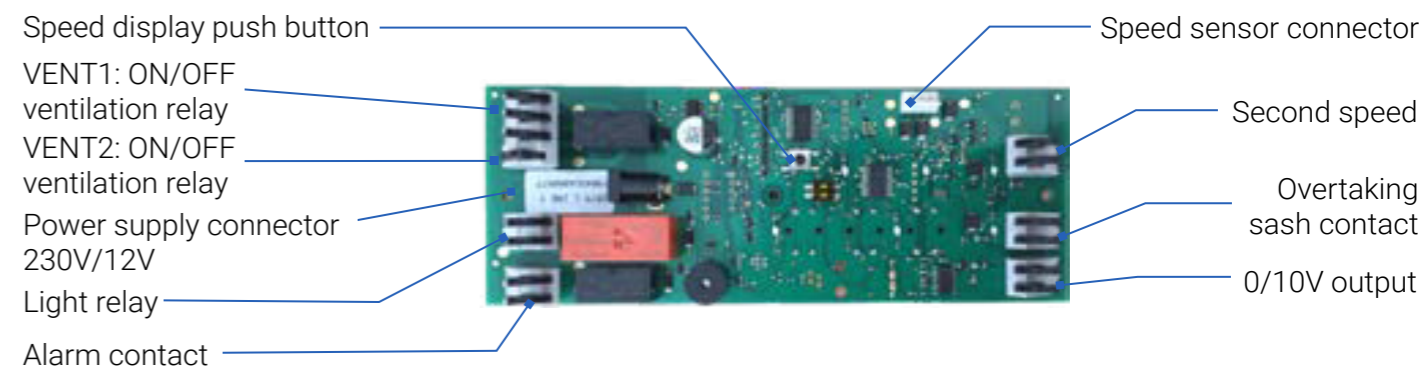

Fully Integrated Controller: Type C2 - Speed

Diagram

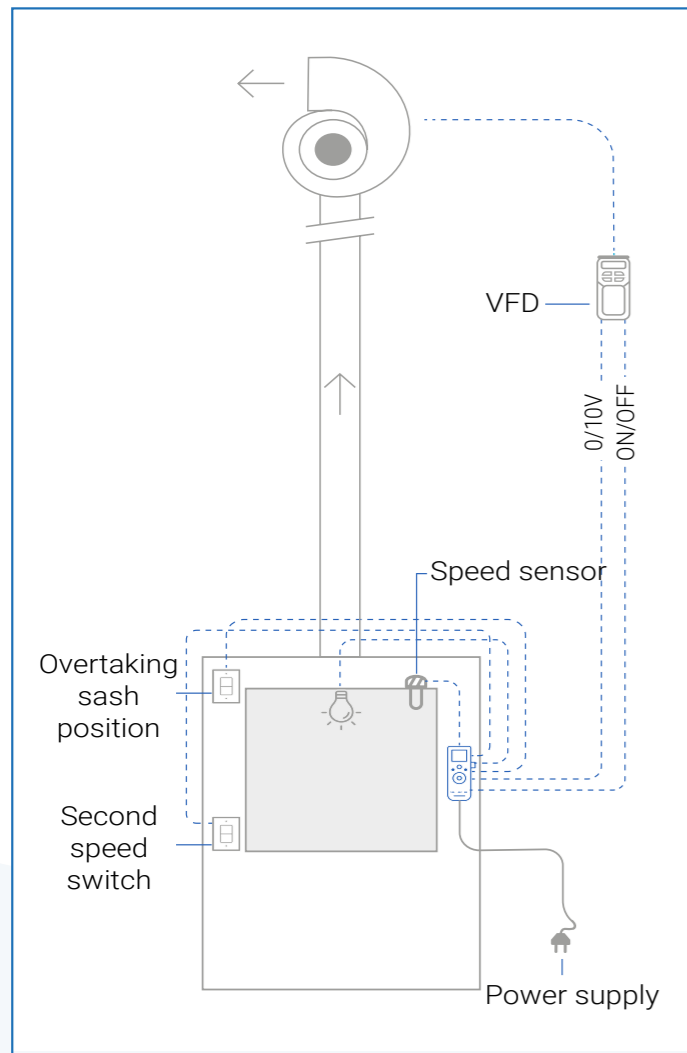

Pressing the ON/OFF ventilation button on the HMI controls a fan and/or a motorised damper via the two relays VENT 1 and VENT 2.

It allows regulation of the ventilation according to 2 operating points determined by the position of the sash.

- In the low position, the controller sends a first fixed voltage.
- In high position, the controller sends a second fixed voltage.

The switch allows to alternate from one speed to another. The controller ensures both the safety of the operator and an important energy saving.

The green LED is lit when the face velocity is sufficient.

The red LED flashes when the face velocity is insufficient.

The orange «sash overrun» LED lights up if the sash is raised above the maximum safe working opening. This fault is triggered by a position switch.

If a failure remains within a period of time of 15-30s, the audible alarm will activate. Having identified the problem, the laboratory personnel can stop the alarm by pushing the stop buzzer button.

Pressing the light ON/OFF button controls the lighting via a 250V 16A relay.

The controller is supplied with a 230V/12V power adaptor and is factory preset to 0.5m/s. It can be reset on site using an anemometer.

Options

- Available in vertical or horizontal version
- Available in digital display version (m/s)
- Battery
- Alarm relay
- Temperature sensor
- Night setback
- Speed sensor with 5 metres wire

Operating Principal

The TYPE C 2-speed flow controller controls the airflow of a fume hood. Three push buttons are used to control the ventilation, the lighting and to stop the alarm.

Control SEAT



The CONTROL SEAT is a safety device for controlling the ventilation of a fume hood. It adjusts the ventilation to maintain the set speed regardless of the sash height. It informs the user with visual and audible alarms if a malfunction occurs. The remote HMI enables adjustments on site and controls the fume hood ventilation. It has many operating modes and can be combined with a linear position sensor.

Benefits

- Digital display of speed and/or flow rate
- Remote HMI with small dimensions to control the fume hood ventilation and to make adjustments on site
- Energy savings: reduction of exhaust air by regulation
- Flexibility: the fan can be set to any speed
- User comfort: low air velocities ensure low noise levels
- Easy to use, install and maintain
- Visual and audible alarms
- Pre-calibrated to 0.5m/s
- EN 14175 compliant

This controller is EN14175 and RoHS compliant	HMI Dimensions 115x65x18	CPU Dimensions 241x182x65
---	--------------------------	---------------------------

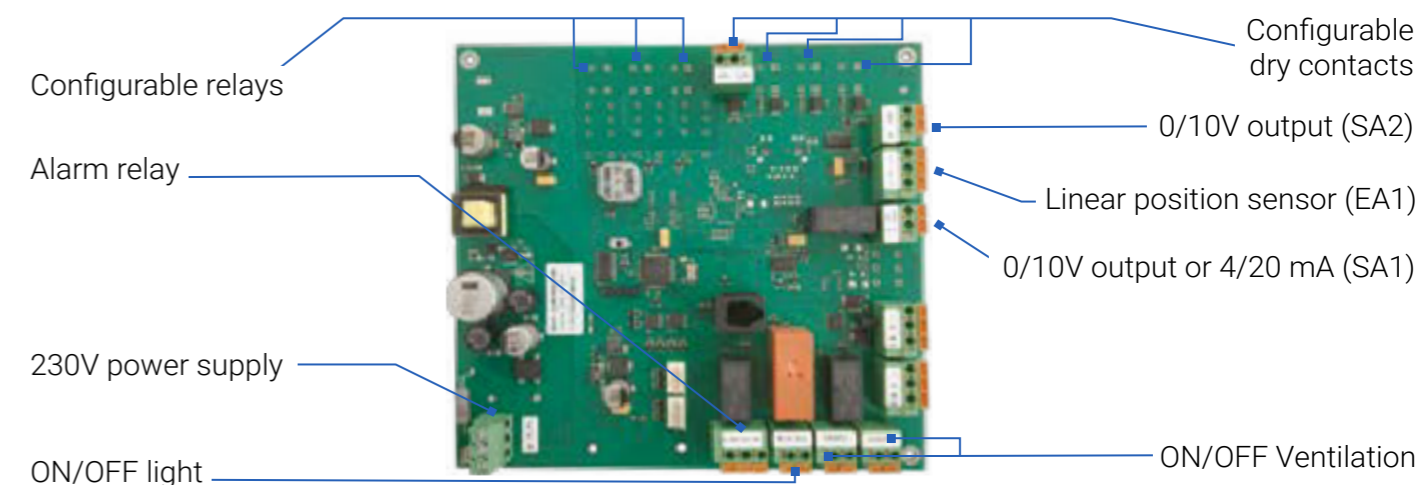

Control SEAT

Diagram

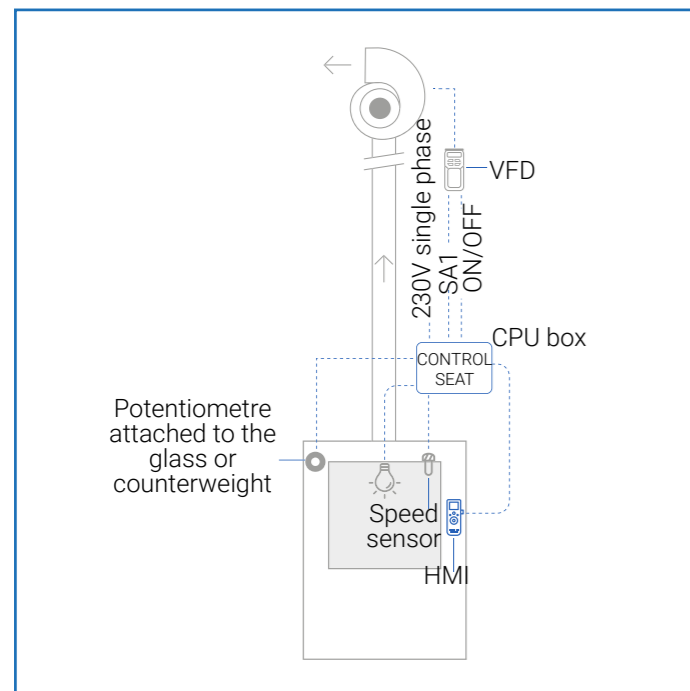

These outputs can be controlled by the HMI push buttons, by the configurable inputs or by window heights.

Operating Principal

The Control E-SEAT is used to control the airflow of the fume hood. Six push buttons are used to control the ventilation, the lighting, priority speed, navigate menus and to stop the alarm.

Pressing the ON/OFF button on the HMI controls a VFD and/or a motorised damper via the two relays VENT 1 and VENT 2.

The control can also be performed with the sensor only (PID controller) or with a position switch (2-speed). The sensor measures the face velocity, which informs the user in case of a fault.

The green LED is lit when the face velocity is sufficient.

The red LED flashes when the face velocity is insufficient.

The orange «sash overrun» LED lights up if the maximum window height is exceeded. This fault is activated by the linear position sensor or by a position switch. The orange LED «auxiliary faults» lights up if the auxiliary input is activated.

The audible alarm is activated after an adjustable delay when a fault is still present. After identifying the cause, the user can turn off this alarm by pressing the stop buzzer button.

Pressing the light ON/OFF button controls the lighting via a 250V 16A relay.

The controller is powered by 230V single phase and is factory preset to 0.5m/s and can be adjusted on site using an anemometer.

Options

- Linear position sensor
- Temperature sensor
- Night setback
- Speed sensor with 5 metres wire

• Additional configurable inputs option

By default the controller is equipped with an EC1 input, but up to 4 inputs are available as options to perform various functions. These inputs can be used, for example, to add remote controls such as emergency stop, priority speed, reduced flow, night setback or second speed. Various sensors can also be connected to these additional inputs. These can control ventilation, light, alarm or configurable outputs.

• Additional configurable outputs option

Up to 3 additional outputs are available as options. These are relay outputs (NO 250V 0.3A) that can be used to control all kinds of electrical equipment such as solenoid valves, drives and motors that require dry contact control.

Modular Controller: Control E - SEAT



The CONTROL E-SEAT is a communicating safety device for controlling the ventilation of a fume hood. It adjusts the ventilation to maintain the selected speed set point regardless of the sash height. It informs the user with visual and audible alarms if a malfunction occurs. The remote HMI enables adjustments on site and controls the fume hood ventilation. It has many operating modes and can be associated with a linear position sensor. A MODBUS connection is provided to link all CONTROL E-SEAT boards and interface them with a CAPTUR E-SEAT board and/or a CTM.

Benefits

- Communicating controller: MODBUS link
- Digital display of speed and/or flow rate
- Remote HMI with small dimensions to control the fume hood ventilation and to make adjustments on site
- Energy savings: reduction of exhaust air by regulation
- Flexibility: the fan can be set to any speed
- Comfortable to use: low air speeds ensure low noise levels
- Easy to use, install and maintain
- Visual and audible alarm
- Pre-calibrated to 0.5m/s
- EN 14175 compliant

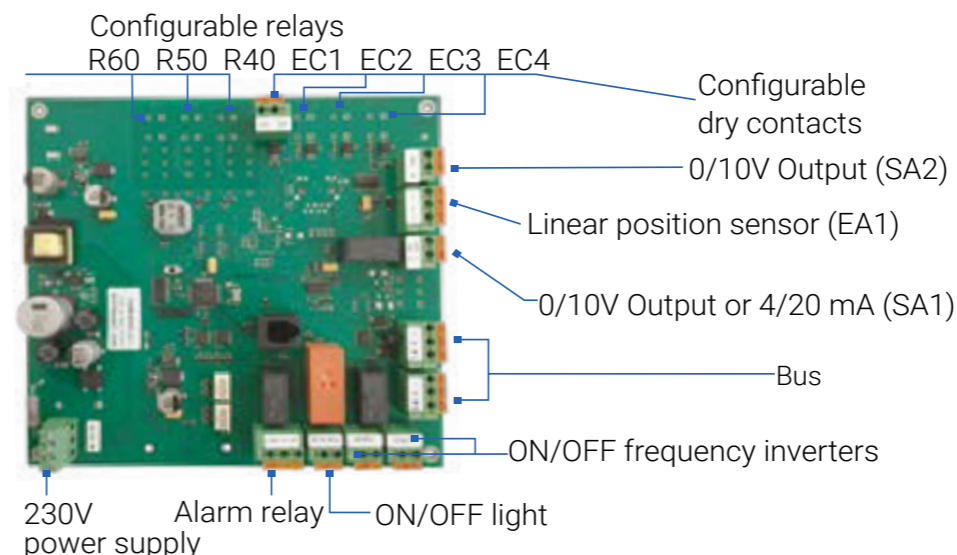

CPU Dimensions
24x182x65

HMI Dimensions
115x65x18

This controller is EN14175 and RoHS compliant

Modular Controller: Control E - SEAT

Diagram

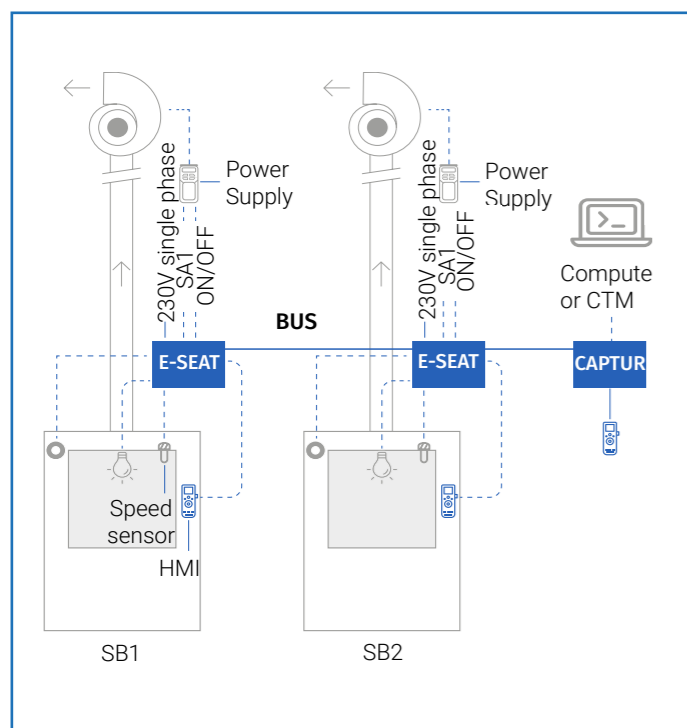

be controlled by the interface buttons, by the configurable inputs or by window heights.

Operating Principal

The Control E-SEAT is used to control the airflow of the fume hood. Six push buttons are used to control the ventilation, the lighting, priority speed, navigate menus and to stop the alarm.

Pressing the ON/OFF button on the HMI controls a VFD and/or a motorised damper via the two relays VENT 1 and VENT 2.

The control can also be performed with the sensor only (PID controller) or with a position switch (2-speed). The sensor measures the face velocity, which informs the user in case of a fault.

The green LED is lit when the face velocity is sufficient.

The red LED flashes when the face velocity is insufficient.

The orange «sash overrun» LED lights up if the maximum window height is exceeded. This fault is activated by the linear position sensor or by a position switch.

The orange LED «auxiliary faults» lights up if the auxiliary input is activated.

The audible alarm is activated after an adjustable delay when a fault is still present. After identifying the cause, the user can turn off this alarm by pressing the stop buzzer button.

Pressing the light ON/OFF button controls the lighting via a 250V 16A relay.

The controller is powered by 230V single phase and is factory preset to 0.5m/s. It can be adjusted on site using an anemometer.

Options

- Temperature sensor
- Night setback
- Speed sensor with 5 metres wire

• Additional configurable inputs option

By default the controller is equipped with an EC1 input, but up to 4 inputs are available as options to perform various functions. These inputs can be used, for example, to add remote controls such as emergency stop, priority speed, reduced flow, night setback or second speed. Various sensors can also be connected to these additional inputs. These can control ventilation, light, alarm or configurable outputs.

• Additional configurable outputs option

Up to 3 additional outputs are available as options. These are relay outputs (NO 250V 0.3A) that can be used to control all kinds of electrical equipment such as solenoid valves, drives and motors that require dry contact control. These outputs can

Modular Controller: L.COM E - SEAT



The L.COM E-SEAT board allows to control the airflow of exhaust arms, fume hoods and other ventilated stations with fixed airflow in a laboratory. Up to 3 extraction stations can be connected to the same controller with a programmable flow rate per station (P1, P2, P3). The remote HMI enables adjustments on site and controls the fume hood ventilation. A MODBUS connection is provided to link all the L.COM E-SEAT boards with the CONTROL E-SEAT and interface them with a CAPTUR E-SEAT board and/or a BMS.

Benefits

- Communicating controller: MODBUS link
- Control of 1 to 3 stations with a specific flow rate for each station
- Control of a station with 3 different flow rates

This controller is EN14175 and RoHS compliant	HMI Dimensions 130x40x24	CPU Dimensions 241x182x65
---	-----------------------------	------------------------------

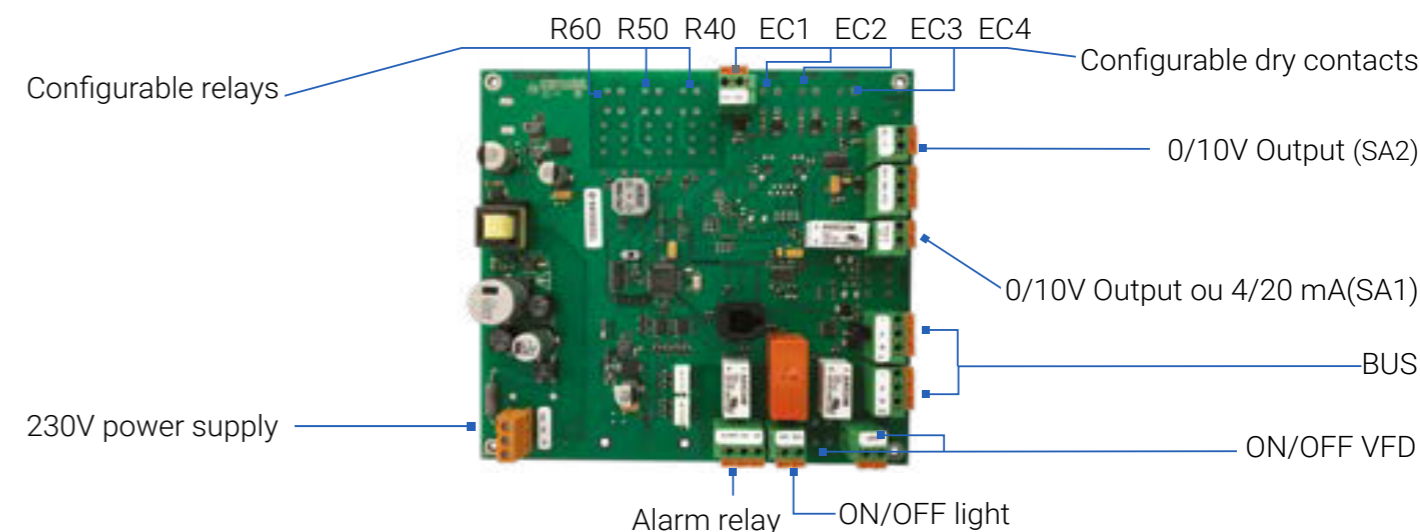

Modular Controller: L.COM E - SEAT

Diagram

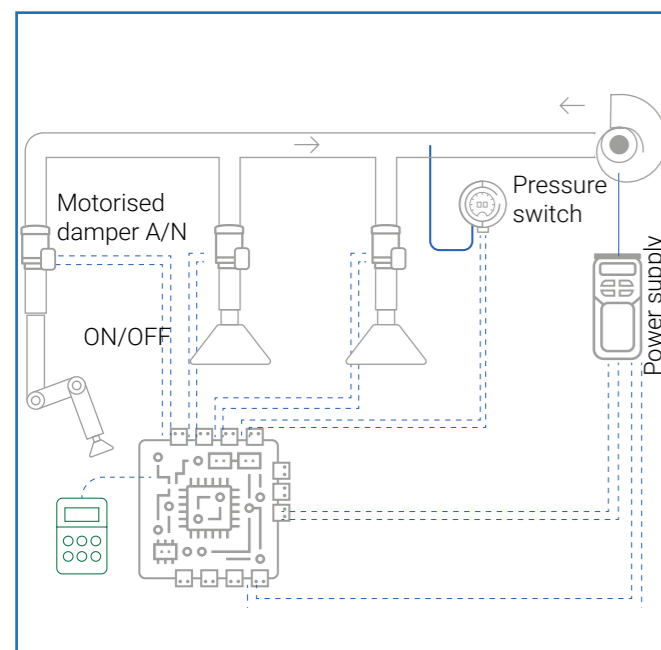

Options

- Alarm relay
- Night setback
- Pressure switch (REF 819711)
- Optional alarm relay and battery backup
- Configurable inputs

Additional configurable inputs option

By default the controller is equipped with an EC1 input, but up to 4 inputs are available as options to perform various functions. These inputs can be used, for example, to add remote controls such as emergency stop, priority speed, reduced flow, night setback or second speed. Various sensors can also be connected to these additional inputs. These can control ventilation, light, alarm or configurable outputs.

Additional configurable outputs option

Up to 3 additional outputs are available as options. These are relay outputs (NO 250V 0.3A) that can be used to control all kinds of electrical equipment such as solenoid valves, drives and motors that require dry contact control. These outputs can be

controlled by the interface buttons, by the configurable inputs or by window heights.

Operating Principal

The L.com E-SEAT is used to control the airflow of exhaust arms and fume hoods. Six push buttons are used to control the ventilation, the lighting, priority speed, navigate menus and to stop the alarm.

Configuration 1 :

Up to 3 ventilation stations can be connected to the same controller with a programmable flow rate per station. The push buttons 3, 4 and 6 then control the ventilation of stations 1, 2 and 3 respectively.

Configuration 2 :

Several extraction flows can be configured on a single exhaust station. Each button (3,4,6) is associated with a configurable flow rate. Pressing one or more of these buttons activates the VFD and/or a motorised damper via the two relays VENT 1 and VENT 2.

An optional pressure switch can be connected to inform the user in case of ventilation failure.

The green LED lights up when the pressure is sufficient.

The red LED flashes when the pressure is insufficient.

The orange LED «auxiliary faults» lights up if the auxiliary input is activated.

The audible alarm is activated after an adjustable delay when a fault is still present. After identifying the cause, the user can turn off this alarm by pressing the stop buzzer button.

Pressing the ON/OFF light button controls the lighting via a 250V 16A relay.

The controller is powered in 230V single phase.

Modular Controller: Captur E - SEAT



The CAPTUR E-SEAT board ensures a global management of the laboratory by controlling both the extraction and air supply. It centralises the information from the CONTROL E-SEAT and/or L.COM E-SEAT boards via a MODBUS interface and sends them to an AHU and/or a BMS. It can also dialogue with a PC via an Ethernet TCP/IP connection. The CAPTUR E-SEAT board allows to control of up to 31 fume hoods or other exhaust stations directly from the HMI or from a monitoring software on PC. It recovers information on flow rates, defaults, and emits visual and audible alarms in case of malfunctions.

Benefits

- Two MODBUS link
- Two configurable 0/10V outputs
- TCP/IP ethernet links
- Overall control of a laboratory
- Control of several laboratories
- Connection to Supervision software

This controller is EN14175 and RoHS compliant	HMI Dimensions 130x40x24	CPU Dimensions 241x182x65
---	-----------------------------	------------------------------

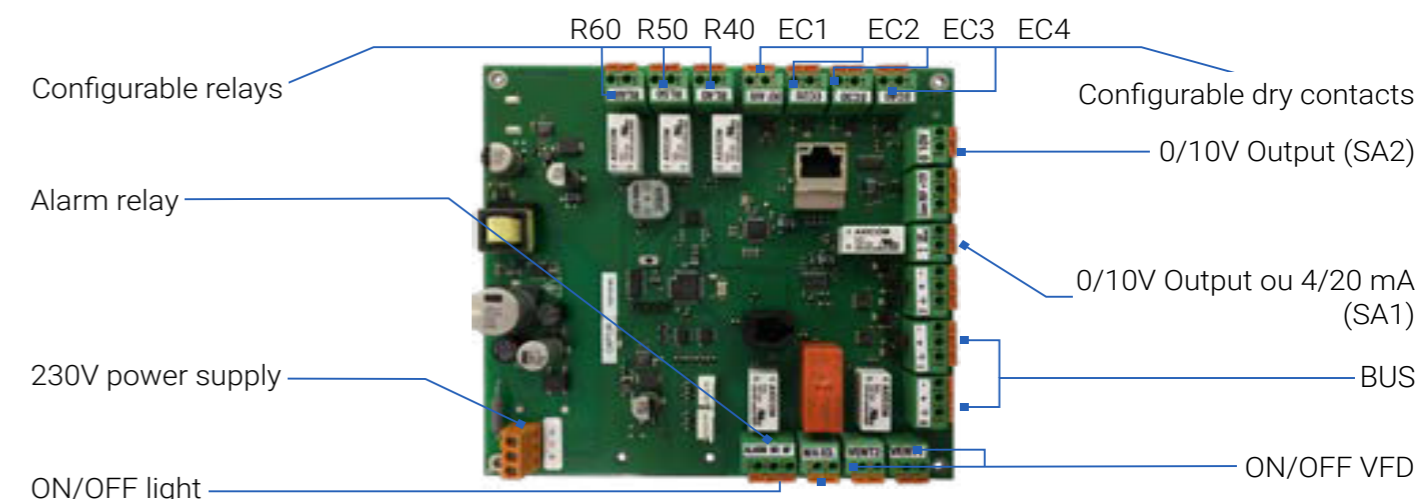

Modular Controller: Captur E - SEAT

Diagram

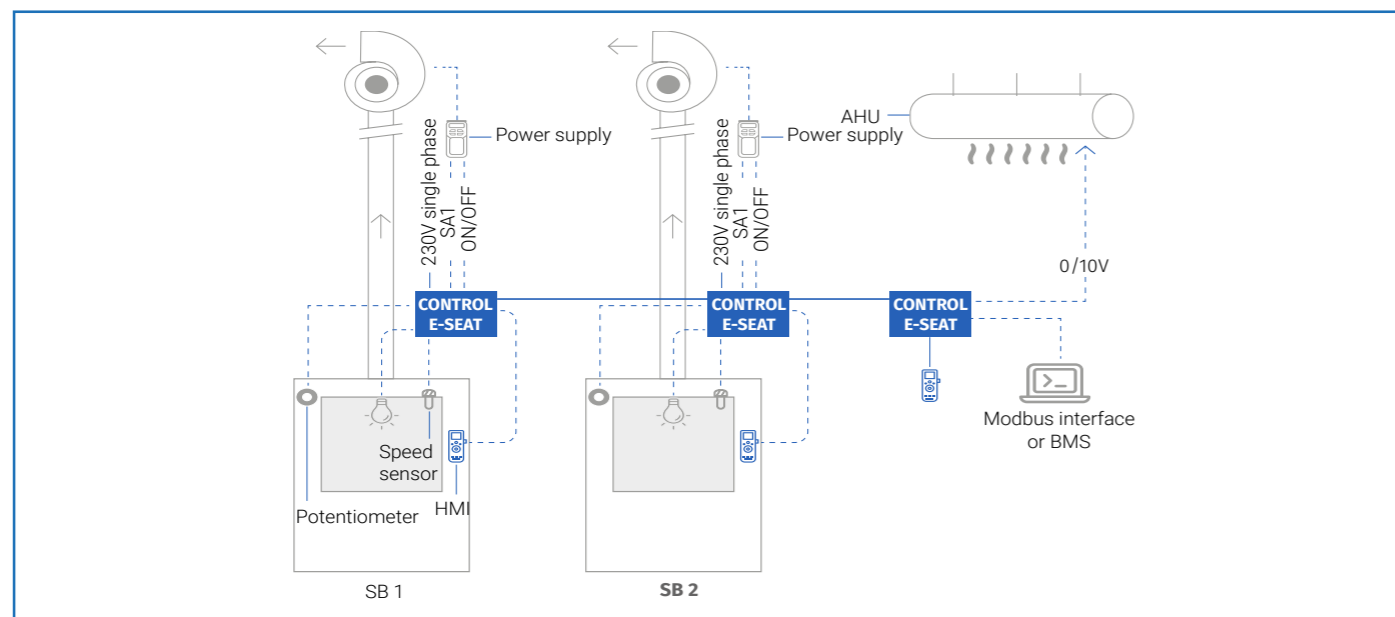

Operating Principle

The CAPTUR E-SEAT board is a remote control flow summing device. It enables the user to control the Control E-SEAT and L.COM E-SEAT boards installed on fume hoods, exhaust arms and exhaust hoods. It recovers the flow rates of each CONTROL E-SEAT and L.COM and sends back a 0/10V signal at the room air supply, signal which is proportional to the extraction.

The 0/10V outputs can be adjusted with a coefficient in order to have a more accurate setting. It has a second MODBUS link to communicate with a BMS, and also an Ethernet TCP/IP link to communicate with a monitoring software. A remote HMI allows to control the functioning of all the connected boards.

- ON/OFF Light
- ON/OFF ventilation
- Priority speed
- Stop alarm
- Configurable push buttons

The control of these functions can also be done through the supervision software connected to the RJ 45 of the CAPTUR E-SEAT.

The controller is powered by single phase 230V.

The CAPTUR E-SEAT board has 4 configurable inputs to perform various functions such as emergency stop, priority speed, reduced flow or night watch.

Different sensors can also be connected to these additional inputs which can control ventilation, light, alarm or configurable outputs.

It has 3 output relays (NO 250V 0.3A) which allow to control all kinds of electrical equipment requiring a dry contact control such as solenoid valves, inverters, motors and dampers. These outputs can be controlled by the interface buttons or by the configurable inputs.

Options

Two SUPERVISION software options are available for Windows PC. This enables you to centralise all the useful data for the management of laboratories and stations. It is possible to remotely control each station or an entire laboratory and is the ideal tool to maintain laboratories on a daily basis.

Safety Cabinet Controller

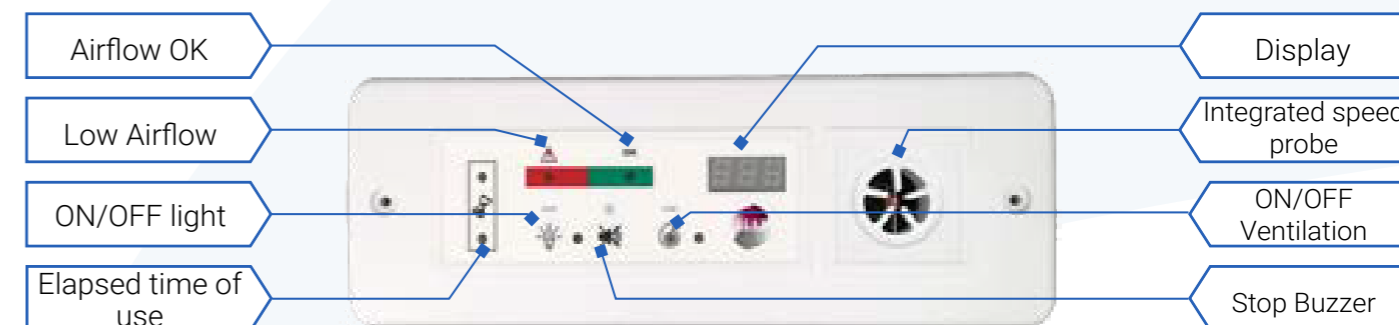

The enclosed controller measures the working time of the extraction in the ventilated enclosure. If the timespan is inferior to 5% of the initial setting time, 2 orange lights flash to notify the lab assistant. When the operating time has elapsed, the controller informs the users by displaying «FIL» (abbreviation of: filters to be changed), and triggers two alarms: an audible alarm and a visual alarm (the two orange LEDs remain lit). In the event of an extraction failure (insufficient suction, open door, blocked filter, air flow failure...), The red LED flashes and the sound alarm is activated. If the flow is sufficient the green LED comes on. Airflow, lighting, and the stop buzzer are controlled by 3 push switches.

Benefits

- Simple interface for ventilation and light control
- Visual and audible alarm in case of ventilation failure
- Can be adjusted to suit any ventilation system
- Accurate probe measurements

Options

- Alarm relay
- Temperature sensor
- Remote speed probe (3.5m or 5m)

This controller complies with EN14175 and the work regulation R4222-13

HMI Dimensions 210x75x34

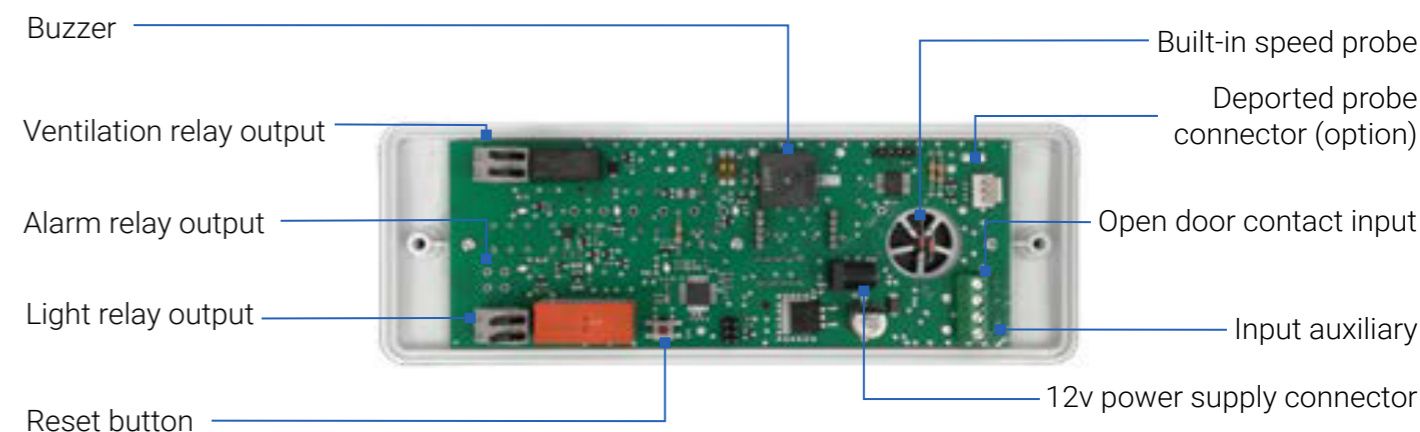

Storage Cabinet Controller

This controller is used to check the correct operation of the extraction of a chemical storage cabinet. In case of an extraction fault (insufficient suction, open door, clogged filter, fan failure), the red LED flashes and the acoustic alarm is activated. If the flow rate is sufficient, the green LED is lit. The installation of this product requires the drilling of a panel or door in the cabinet.



Benefits

- Simple interface for ventilation and light control
- Visual and audible alarms in case of ventilation failure
- Can be adjusted to suit any ventilation system
- Accuracy of probe measurement

Options

- Alarm relay
- Temperature sensor
- Remote speed probe (3.5m or 5m)

Automatic Inactivity Controller: ECOGLASS

Operating Principle

ECOGLASS is an efficiency optimised system designed to reduce fume hood energy consumption by automatically closing a moveable sash after detecting inactivity. A motion sensor detects the activity of laboratory personnel and the presence of objects in the path of the sash. The ECOGLASS controller recognises and acts upon a period of pre-programmed inactivity and automatically triggers the lowering command to close the sash to its lowest point. A magnetic compensator releases the sash and controls its descent to the end of its path. A safety device then interrupts the descent in case of activity or objects in the sashes path while a control switch allows laboratory operatives to disengage the magnetic compensator, allowing them to operate the sash.

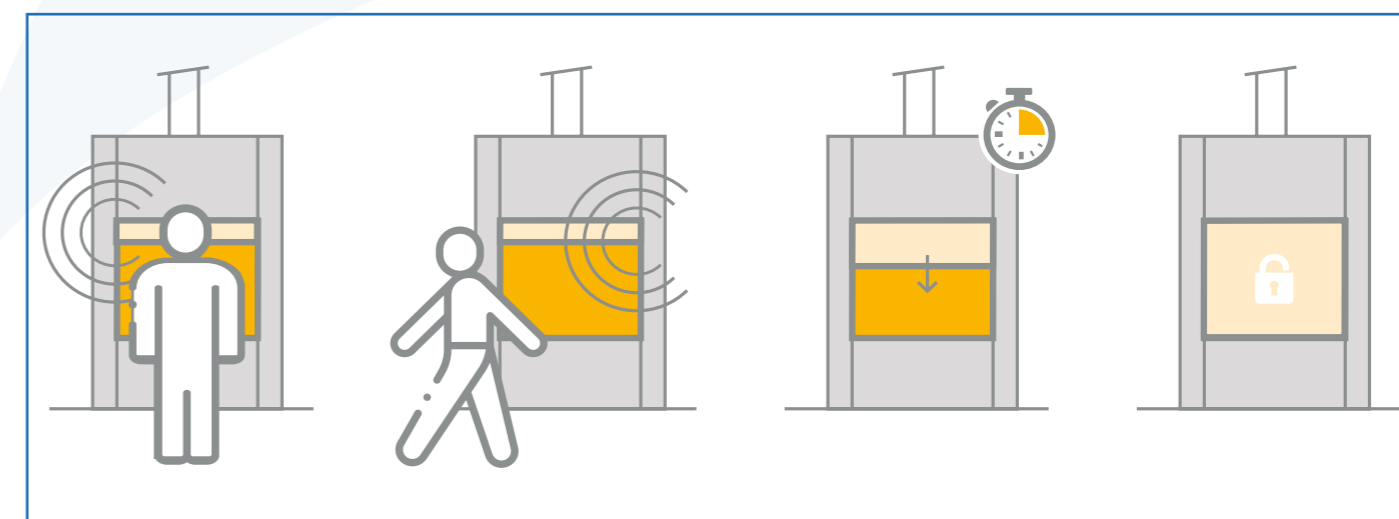

This controller complies with EN14175 and the work regulation R4222-13

Detection zone dimensions (H)0.40m X (W)2.5m



Automatic Inactivity Controller: ECOGLASS

DIAGRAM

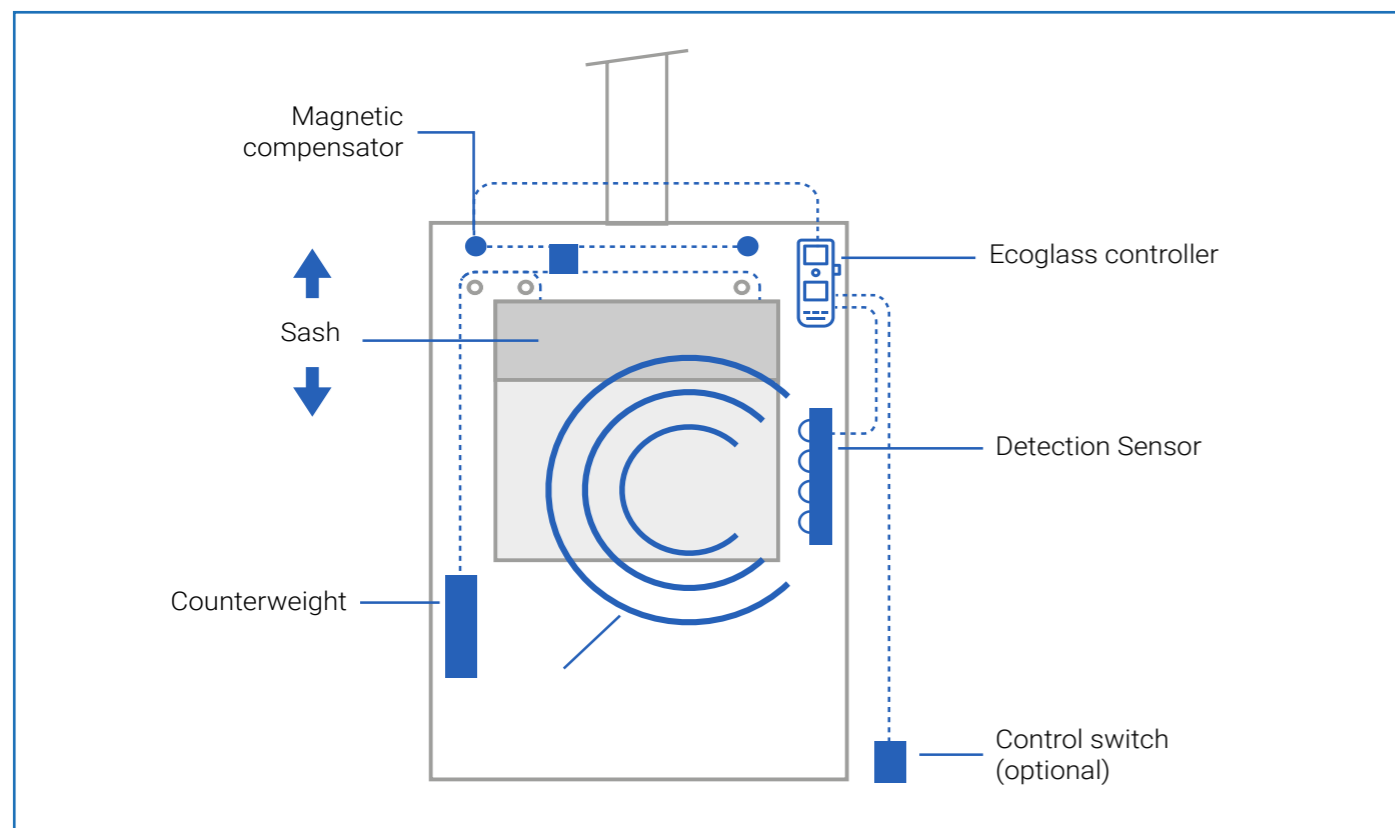

Features

• Automatic closing

After a configurable period of inactivity, whatever the initial position of the window, it is closed to its lowest point. The detection sensor can be installed on the front of the sash or flush-mounted

• Inactivity sensor

Movement generated by a weight imbalance between the sash and its counterweight

• No motorisation

Ecoglass allows the handling of the fume hood with or without power and ensures that the glass remains in position

• Installation

Different configurations are possible depending on the position of the counterweight and the type of mechanisms (compatible with cable or belt transmission)

Benefits

- Automatic descent without motorisation
- Adapts to all movable sash mechanisms
- Quick installation without modification of the fume hood

Our Stock Policy

In 2020 we extended our warehouse to enable us to increase our stock holding of our most popular industrial fans and accessories for the corrosive fume market.

This means we now carry stock of all of our single and three phase polypropylene fans with standard AC motors, energy efficient EC motors or ATEX configurations to enable us to service our UK customers.

Our customers benefit from short lead times and unrivalled stock availability on an extensive range of fume fans with accessories to facilitate.

We're confident that our stock and logistics policy enables us to maintain a position that will provide continuity of business and a cost effective solution to industrial corrosion resistant fan procurement for our ever growing customer base.

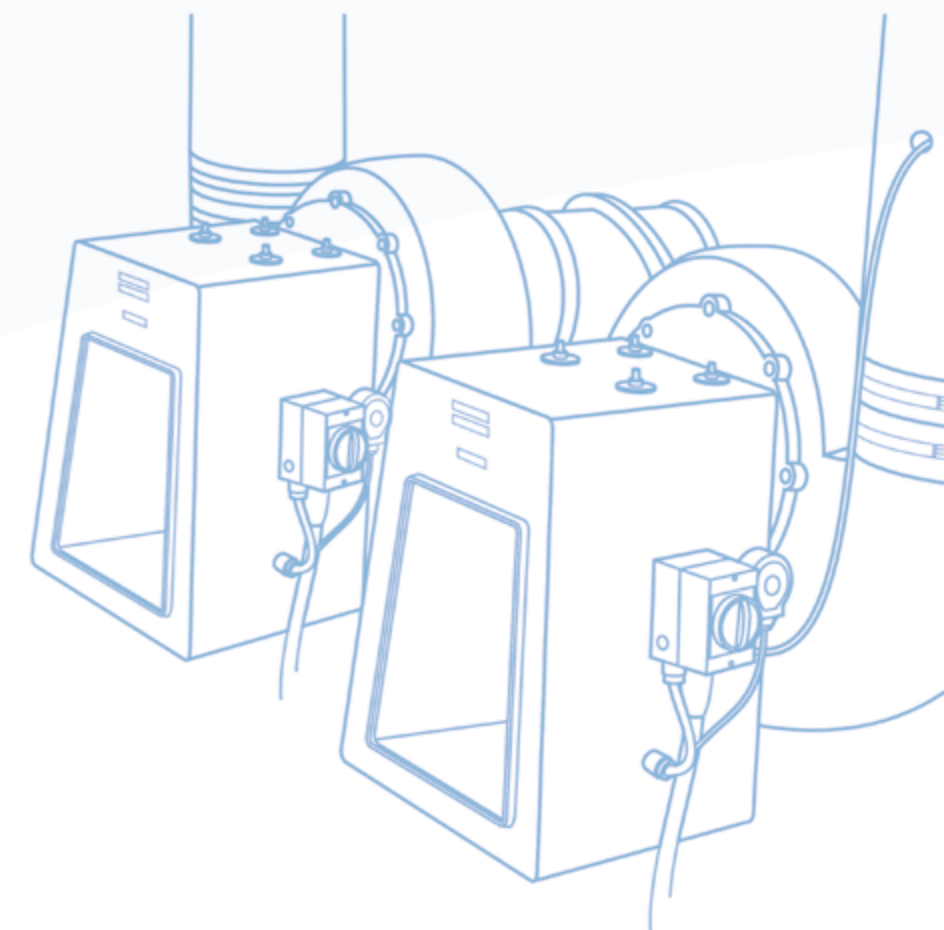

Technical Understanding

We understand key influencing factors affecting the fume extraction and corrosive air market including fan energy consumption and calculating system resistance. We ensure we meet the total specification of your project.

Stocked Lines

We stock a wide range of single and three phase polypropylene fan variants in addition to an extensive range of other industrial fans for key UK market sectors. We pledge to ensure our stock levels are maintained for our customers.

Short Lead Times

Stock available for immediate despatch ensures short lead times on popular lines. Those with scheduled orders continue to rely on Axair to manage their delivery schedules. On non stocked lines our lead times are competitive.



Contact Us

Whatever your issue, concern or question, contact our industrial team using the below contact details. Alternatively, visit our website and open a live chat to start discussions.

01782 349 430

sales@axair-fans.co.uk