

Plug Fans with Generation 3 EC Motor*

The E Series range of Plug Fans produce significant increases in energy efficiency and a major reduction in operating noise in high flow and low-medium pressure applications. Available from stock or on short lead times, in multiple single & 3 phase EC variants.

Modular EC Plug Fans (GKHM)

Compact, efficient and optimally designed, the GKHM range of EC modular plug fans feature a lightweight (1.22kg/m²) black UV stabilised, long fibre reinforced polypropylene impeller, therefore reducing the mass of inertia and start up resistance to a minimum. Designed with computer fluid dynamics, the profiled blades and diffuser wheel produces less vibration while significantly reducing noise levels.



Generation 3 EC Motor*

The Generation 3 EC motor from Rosenberg is 30% more powerful than the previous generation. As standard, the motors input voltage range is 200-480 VAC (50/60Hz) and offers additional upgrades such as an integrated inspection LED to visualise the motors condition, improved ModBus RTU functionality, electronic quick change technology (EQC), IT network support. The maximum electrical input power is 4.7kW. *Featured on 3 phase fans only.



“ The E Wheel is geared for maximum performance and efficiency. The optimised inlet conditions reduce the motor interaction with the airflow path, resulting in an increased airflow and pressure.”

Key Features & Benefits

Expertly designed and manufactured to the highest standards by The Rosenberg Group in Germany, the GKHM range blends efficiency, performance and costs perfectly. A full range of datasheets are available upon request, contact us for more information.

Energy Efficient E-Wheel (CIE)

The E-Wheel is manufactured from state-of-the-art materials and developed in house by Rosenberg Group. The E series revolution produces class leading performance in a backward curve offering. Efficiency is optimised by using 7 profiled blades and a narrow radial diffuser to maximise static regain through the fan discharge.

Higher Performance (IE)

E-Wheel is geared for maximum performance and efficiency, to achieve this we have optimised inlet conditions by reducing the motor interaction with the airflow path as much as possible, this has resulted in increased airflow and pressure vs our non-optimised solution.

EC Generation 3 Motor (Gen 3)

The Gen 3 EC motor from Rosenberg is 30% more powerful than the Gen 2 equivalent and allows for an input voltage of 200-480 VAC, 50/60Hz in the same reference.

Low Cost & Low Noise

Competitively priced, the E-Wheel is a cost effective, low noise solution that is adopted by many UK air handling manufacturers.

“**The Generation 3 motor allows for an input voltage of 200-480 VAC in the same reference.**”

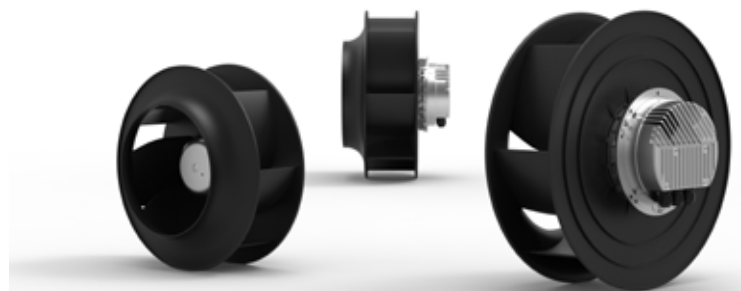

GKHM 280-CIE.065.4EA IE HP	N43-28001
GKHM 315-CIE.088.4EA HP	N43-31508
GKHM 355-CIE.112.5FA IE	N43-35509
GKHM 400-CIE.125.5FA IE	N43-40007
GKHM 500-CIE.154.5HF IE	N43-50014

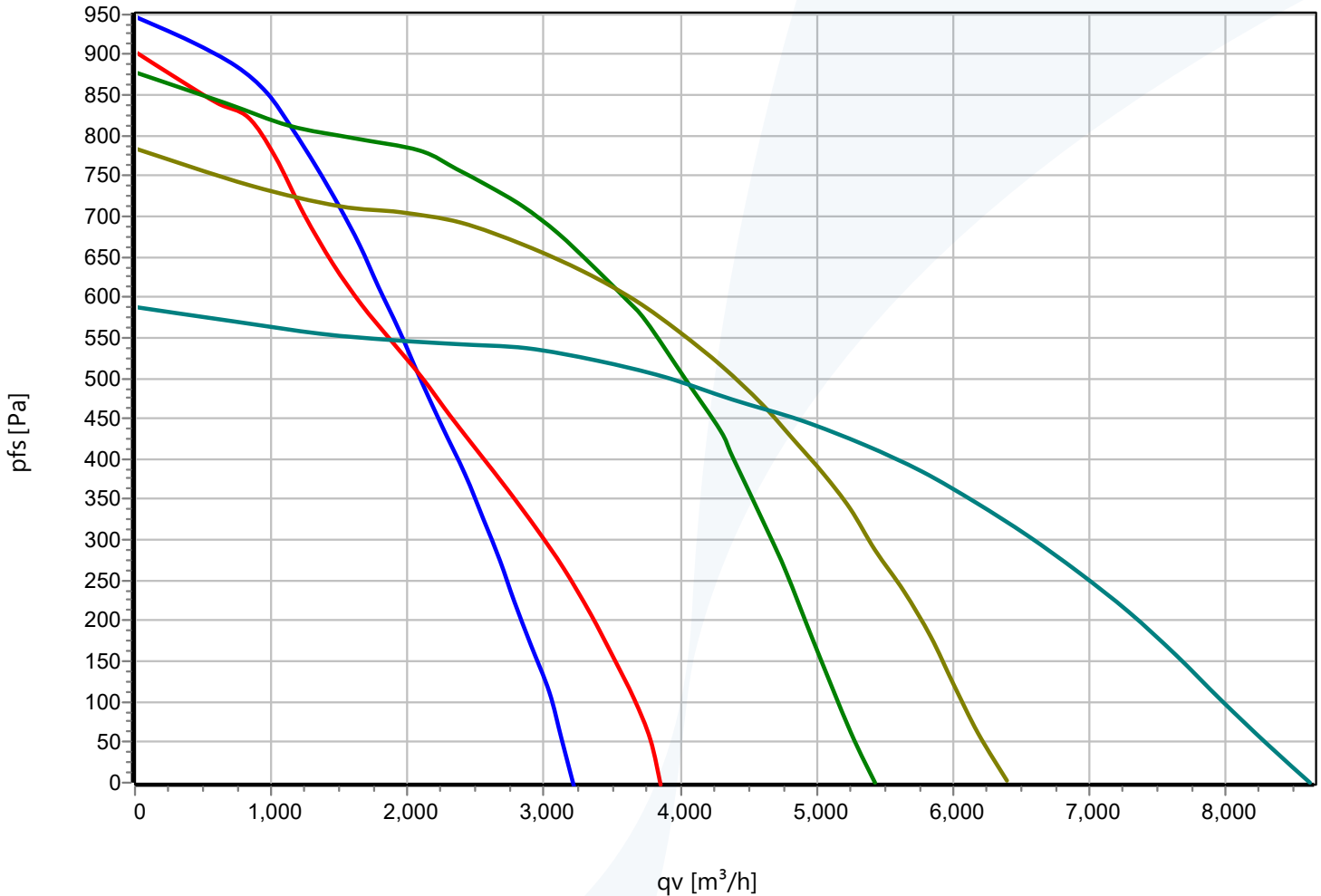

“Our Single Phase EC Plugs Fans are available from stock and ready for immediate despatch.”

Single Phase EC

Single phase EC plug fans come complete with a P5 wiring interface via cable for supply and controlling in addition to integrated active Power factor Correction (PFC). Low motor noise. Unlike our 3 Phase variants, the Single Phase EC plug fans feature a Gen 2 motor.



**Download
Datasheets**

GKHM 355-CIE.112.5FA IE Gen3	N43-35513
GKHM 400-CIE.125.5HF Gen3	N43-40009
GKHM 450-CIE.136.6FF IE Gen3	N43-45019
GKHM 500-CIE.154.6FF IE Gen3	N43-50021
GKHM 560-CIE.175.6IF IE Gen3	N43-56010
GKHM 630-CIE.155.6IF IE Gen3	N43-63001

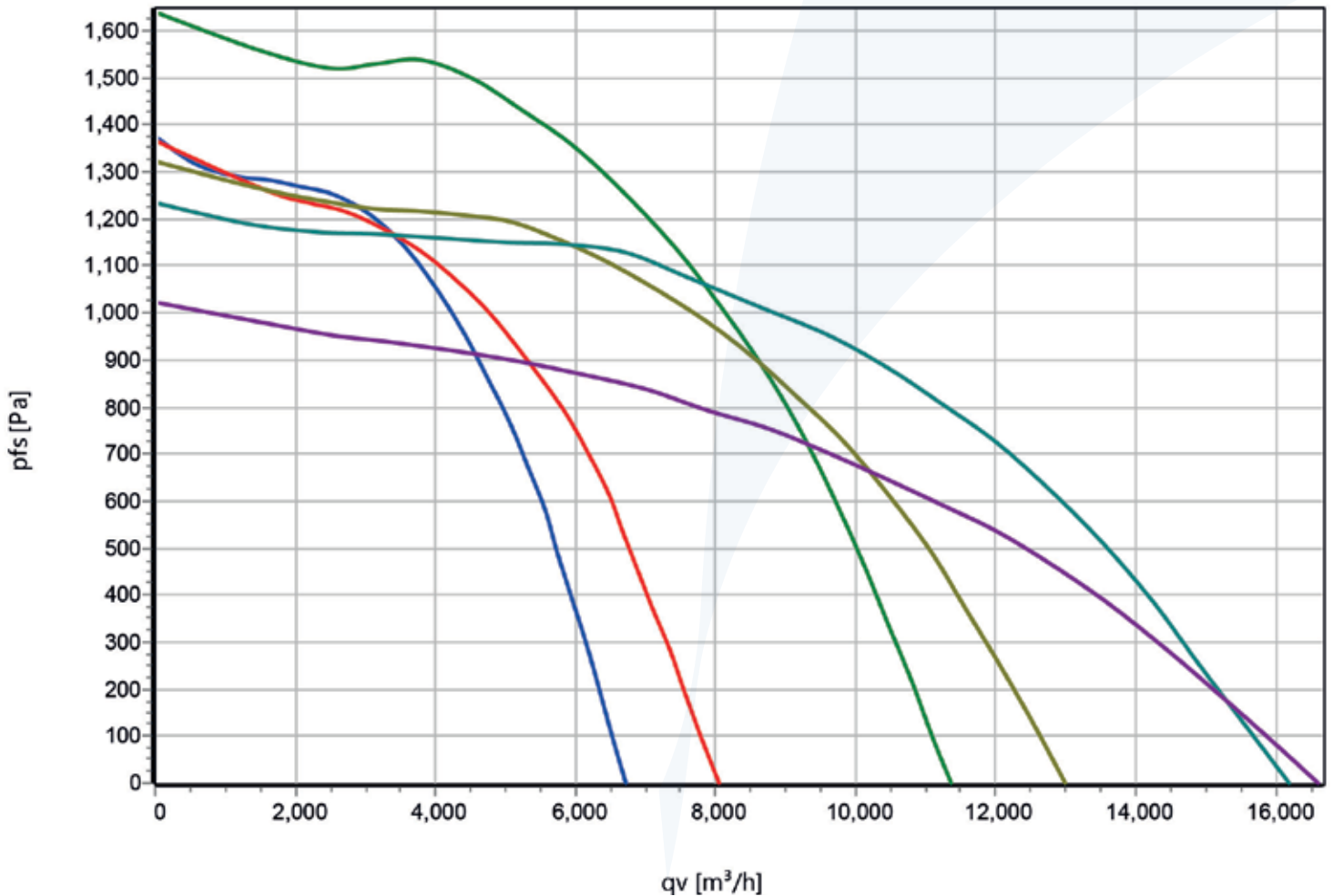

**“Our Three Phase EC Plugs Fans are
 available from stock
 in sizes 355-630ø.”**

Three Phase EC

Three phase EC plug fans come complete with integrated terminal box and environmental resistant cable glands (3x M20x1.5). 100% speed controllable with integrated motor protection. ModBus RTU interface integrated. Busconfiguration possible on site, soft start, potential-free alarm contact and integrated 24V supply for accessories. Low motor noise.



**Download
 Datasheets**

Work with us

*We've been working with air handling manufacturers for over 25 years
We understand the key issues and frustrations that occur in the UK fan market and we're here to support you when you need us.*

“**We understand you, your market and what's important to your business. We're here to support you when you need us.**”



Competitive Quotes

As the UK market introduces price rises due to increased import or export costs, Axair always strives to offer a cost competitive industrial fan offer. We'll advise on price increases within an agreed notice period so you're not let down.



Product Selector



All Rosenberg EC Plug fan information such as operating duties and performance curves can be found on the bespoke RoVent 10 selection software. Simple to download and easy to use. Find the right fan for your application.



Fan Specification

Our Internal team of technical engineers are industry specialists and can help to select the right fan for your application. Talk to our OEM team to discuss your air handling system requirements.

OUR STOCK POLICY

In 2020 we extended our warehouse to enable us to increase our stock holding of our most popular industrial fans for the air handling market.

This means we now carry stock of the most energy efficient and cost effective modular plug fans to service our UK customers.

Our customers benefit from short lead times and unrivalled stock availability while the rest of the market struggles with price increases and long unprecedented lead times.

We're confident that our stock and logistics policy enables us to maintain a position that will provide continuity of business and a cost effective solution to industrial fan procurement for our ever growing customer base.

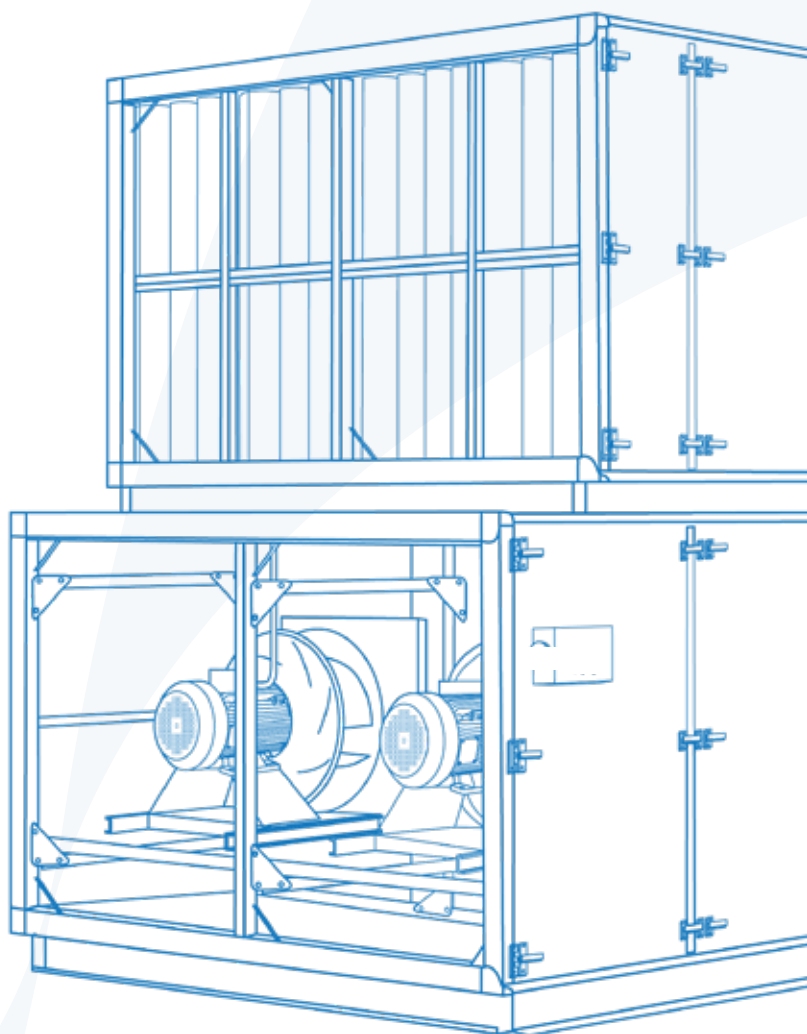

Technical Understanding

We understand key influencing factors affecting the air handling market such as specific fan power, noise calculations, calculating system resistance and ensuring we meet the total specification of your project.



Stocked Lines

We stock a wide range of single and three phase EC Plug Fan variants in addition to an extensive range of other industrial fans for common UK market sectors. We pledge to ensure our stock levels are maintained for our customers.



Short Lead Times

With stock available for immediate despatch we can ensure short lead times on popular lines. Those with scheduled orders continue to rely on Axair to manage their delivery schedules. On non stocked lines our lead times are competitive.